

DATA SHEET

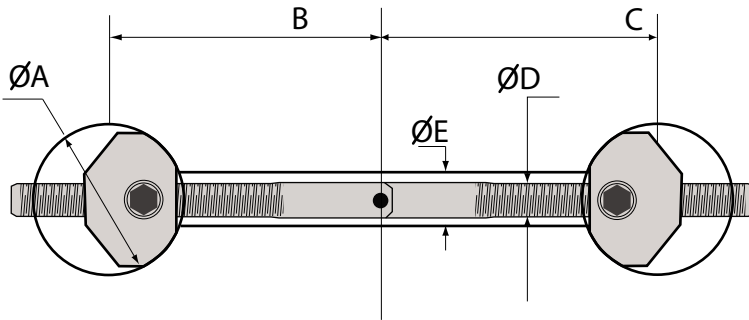

QT 11.700 135mm Mini Full Mitre Connector

SPECIFICATION



SHAFT CENTRE CALCULATION

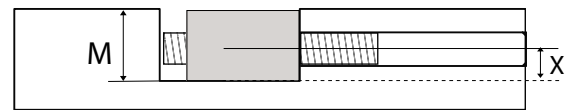

M= Minimum Bore Depth 12.5mm (31/64 inches)
X = Shaft Centre 5.5mm (13/64 inches)

Measurements

	Millimitres	Inches
A	25	1
B	60*	2 ²³ / ₆₄
C	60*	2 ²³ / ₆₄
D	6	15/ ₆₄
E	7	9/ ₃₂



***Note:** The distance from edge of the material to the centre of the 25mm diameter bore hole(A) is 60mm (B). Depending on the angle the material is cut and the depth of the bore hole, this actual distance will vary. The MITRE ZPBOLT has been designed to be adjusted on the full scope of threaded shaft. For further adjustment when drilling the 7mm shaft (E) continue to drill past the 25mm bore hole. This allows the shaft to travel further past the gear head when tensioning MITRE Zipbolt.